

LM3303/LM3403 Quad Operational Amplifiers

General Description

The LM3303 and LM3403 are monolithic quad operational amplifiers consisting of four independent high gain, internally frequency compensated, operational amplifiers designed to operate from a single power supply or dual power supplies over a wide range of voltages. The common mode input range includes the negative supply, thereby eliminating the necessity for external biasing components in many applications.

Features

- Input common mode voltage range includes ground or negative supply
- Output voltage can swing to ground or negative supply

- Four internally compensated operational amplifiers in a single package
- Wide power supply range single supply of 3.0V to 36V dual supply of $\pm 1.5V$ to $\pm 18V$
- Class AB output stage for minimal crossover distortion
- Short circuit protected outputs
- High open loop gain 200k
- LM741 operational amplifier type performance

Applications

- Filters
- Voltage controlled oscillators

Connection Diagram

14-Lead DIP and SO-14 Package

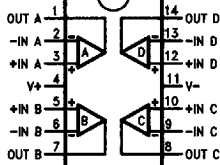

Top View

TL/H/10064-1

Order Information

Device Code	Package Code	Package Description
LM3303J	J14A	Ceramic DIP
LM3303N	N14A	Molded DIP
LM3303M	M14A	Molded Surface Mount
LM3403J	J14A	Ceramic DIP
LM3403N	N14A	Molded DIP
LM3403M	M14A	Molded Surface Mount

Equivalent Circuit (1/4 of Circuit)

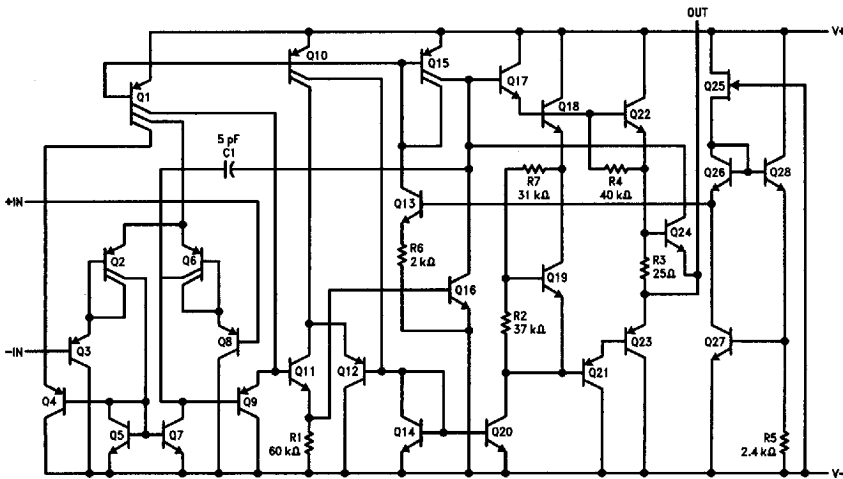

TL/H/10064-2

1-459

■ 6501124 0094754 757 ■

Absolute Maximum Ratings

If Military/Aerospace specified devices are required, please contact the National Semiconductor Sales Office/Distributors for availability and specifications.

Storage Temperature Range

Ceramic DIP	-65°C to +175°C
Molded DIP and SO-14	-65°C to +150°C

Operating Temperature Range

Industrial (LM3303)	-40°C to +85°C
Commercial (LM3403)	0°C to +70°C

Lead Temperature

Ceramic DIP (Soldering, 60 sec.)	300°C
Molded DIP and SO-14 (Soldering, 10 sec.)	265°C

Internal Power Dissipation (Notes 1, 2)

14L-Ceramic DIP	1.36W
14L-Molded DIP	1.04W
SO-14	0.93W

Supply Voltage between V+ and V-

36V

Differential Input Voltage (Note 3)

±30V

Input Voltage

(V-) - 0.3V to V+

ESD Tolerance

(To Be Determined)

LM3303 and LM3403

Electrical Characteristics $T_A = 25^\circ\text{C}$, $V_{CC} = \pm 15\text{V}$, unless otherwise specified

Symbol	Parameter		Conditions	LM3303			LM3403			Units
				Min	Typ	Max	Min	Typ	Max	
V_{IO}	Input Offset Voltage				2.0	8.0		2.0	8.0	mV
I_{IO}	Input Offset Current				30	75		30	50	nA
I_{IB}	Input Bias Current				200	500		200	500	nA
Z_I	Input Impedance			0.3	1.0		0.3	1.0		MΩ
I_{CC}	Supply Current		$V_O = 0\text{V}$, $R_L = \infty$		2.8	7.0		2.8	7.0	mA
CMR	Common Mode Rejection		$R_S \leq 10\text{ k}\Omega$	70	90		70	90		dB
V_{IR}	Input Voltage Range			+12V to V-	+12.5V to V-		+13V to V-	+13.5V to V-		V
PSRR	Power Supply Rejection Ratio				30	150		30	150	$\mu\text{V/V}$
I_{OS}	Output Short Circuit Current (Per Amplifier) (Note 4)			±10	±30	±45	±10	±30	±45	mA
A_{VS}	Large Signal Voltage Gain		$V_O = \pm 10\text{V}$, $R_L \geq 2.0\text{ k}\Omega$	20	200		20	200		V/mV
V_{OP}	Output Voltage Swing		$R_L = 10\text{ k}\Omega$	±12	12.5		±12	+13.5		V
			$R_L = 2.0\text{ k}\Omega$	±10	12		±10	±13		
TR	Transient Response	Rise Time/ Fall Time	$V_O = 50\text{ mV}$, $A_V = 1.0$, $R_L = 10\text{ k}\Omega$		0.3			0.3		μs
		Overshoot	$V_O = 50\text{ mV}$, $A_V = 1.0$, $R_L = 10\text{ k}\Omega$		5.0			5.0		%
BW	Bandwidth		$V_O = 50\text{ mV}$, $A_V = 1.0$, $R_L = 10\text{ k}\Omega$		1.0			1.0		MHz
SR	Slew Rate		$V_I = -10\text{V}$ to $+10\text{V}$, $A_V = 1.0$		0.6			0.6		V/ μs

LM3303 and LM3403 (Continued)

Electrical Characteristics $T_A = 25^\circ\text{C}$, $V_{CC} = \pm 15\text{V}$, unless otherwise specified

The following specifications apply for $-40^\circ\text{C} \leq T_A \leq +85^\circ\text{C}$ for the LM3303, and $0^\circ\text{C} \leq T_A \leq +70^\circ\text{C}$ for the LM3403

Symbol	Parameter	Conditions	LM3303			LM3403			Units
			Min	Typ	Max	Min	Typ	Max	
V_{IO}	Input Offset Voltage				10			10	mV
$\Delta V_{IO}/\Delta T$	Input Offset Voltage Temperature Sensitivity			10			10		$\mu\text{V}/^\circ\text{C}$
I_{IO}	Input Offset Current				250			200	nA
$\Delta I_{IO}/\Delta T$	Input Offset Current Temperature Sensitivity			50			50		$\text{pA}/^\circ\text{C}$
I_{IB}	Input Bias Current				1000			800	nA
A_{VS}	Large Signal Voltage Gain	$V_O = \pm 10\text{V}$, $R_L \geq 2.0\text{ k}\Omega$	15			15			V/mV
V_{OP}	Output Voltage Swing	$R_L = 2.0\text{ k}\Omega$	± 10			± 10			V

LM3303 and LM3403

Electrical Characteristics $T_A = 25^\circ\text{C}$, $V_+ = 5.0\text{V}$, $V_- = \text{GND}$, unless otherwise specified

Symbol	Parameter	Conditions	LM3303			LM3403			Units
			Min	Typ	Max	Min	Typ	Max	
V_{IO}	Input Offset Voltage				8.0		2.0	8.0	mV
I_{IO}	Input Offset Current				75		30	50	nA
I_{IB}	Input Bias Current				500		200	500	nA
I_{CC}	Supply Current			2.5	7.0		2.5	7.0	mA
PSRR	Power Supply Rejection Ratio				150			150	$\mu\text{V}/\text{V}$
A_{VS}	Large Signal Voltage Gain	$R_L \geq 2.0\text{ k}\Omega$	20	200		20	200		V/mV
V_{OP}	Output Voltage Swing (Note 5)	$R_L = 10\text{ k}\Omega$	3.3			3.3			V
		$5.0\text{V} \leq V_+ \leq 30\text{V}$, $R_L = 10\text{ k}\Omega$	(V+) -2.0			(V+) -2.0			
CS	Channel Separation	$1.0\text{ Hz} \leq f \leq 20\text{ kHz}$ (Input Referenced)		-120			-120		dB

Note 1: $T_{J\text{ Max}} = 150^\circ\text{C}$ for the Molded DIP and SO-14, and 175°C for the Ceramic DIP.

Note 2: Ratings apply to ambient temperature at 25°C . Above this temperature, derate the 14L-Ceramic DIP at $9.1\text{ mW}/^\circ\text{C}$, the 14L-Molded DIP at $8.3\text{ mW}/^\circ\text{C}$, and the SO-14 at $7.5\text{ mW}/^\circ\text{C}$.

Note 3: For supply voltage less than 30V between V_+ and V_- , the absolute maximum input voltage is equal to the supply voltage.

Note 4: Not to exceed maximum package power dissipation.

Note 5: Output will swing to ground.

Typical Performance Characteristics

Open Loop Frequency Response

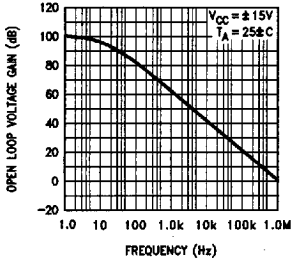

Sine Wave Response

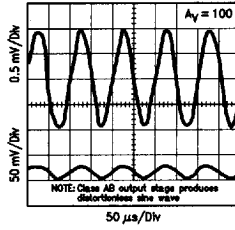

Output Voltage vs Frequency

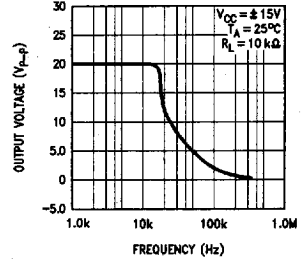

Output Swing vs Supply Voltage

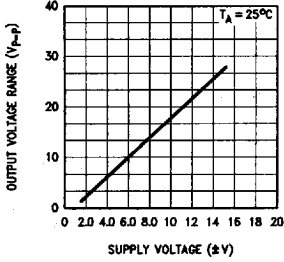

Input Bias Current vs Temperature

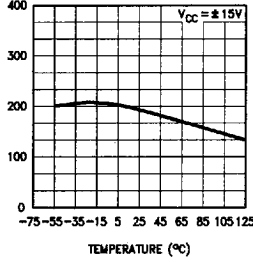

Input Bias Current vs Supply Voltage

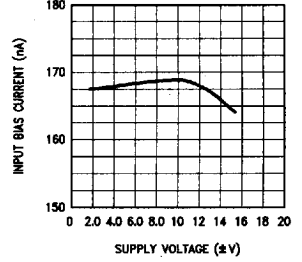

TL/H/10064-3

Typical Applications

Multiple Feedback Bandpass Filter

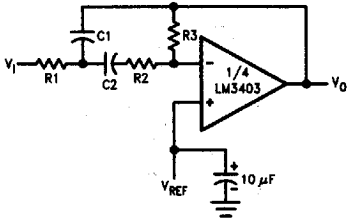

TL/H/10064-4

f_0 = center frequency
 BW = Bandwidth
 R in k Ω
 C in μ F

$$Q = \frac{f_0}{BW} < 10$$

$$C1 = C2 = \frac{Q}{3}$$

$R1 = R2 = 1 \ R3 = 9Q^2 - 1$ } Using scaling factors in these expressions.

If source impedance is high or varies, filter may be preceded with voltage follower buffer to stabilize filter parameters.

Design example:

given: $Q = 5, f_0 = 1$ kHz
 Let $R1 = R2 = 10$ k Ω
 then $R3 = 9(5)^2 - 10$
 $R3 = 215$ k Ω

$$C = \frac{5}{3} = 1.6$$
 nF

Wein Bridge Oscillator

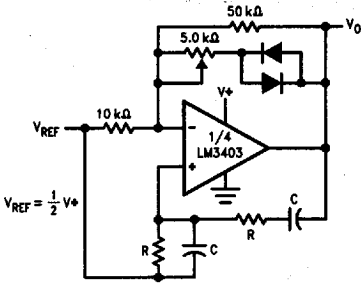

TL/H/10064-5

$f_0 = \frac{1}{2\pi RC}$ for $f_0 = 1$ kHz
 R = 16 k Ω
 C = 0.01 μ F

Comparator with Hysteresis

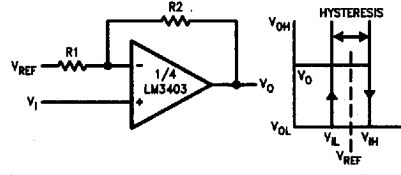

TL/H/10064-8

$$V_{IL} = \frac{R1}{R1 + R2} (V_{OL} - V_{REF}) + V_{REF}$$

$$V_{IH} = \frac{R1}{R1 + R2} (V_{OH} - V_{REF}) + V_{REF}$$

$$H = \frac{R1}{R1 + R2} (V_{OH} - V_{OL})$$

High Impedance Differential Amplifier

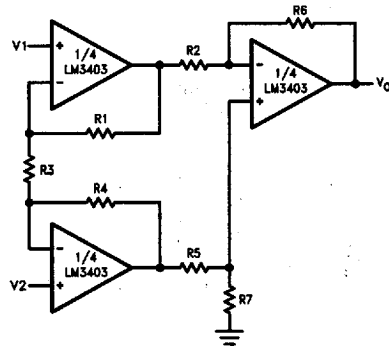

TL/H/10064-7

$$V_{OUT} = C(1 + a + b)(V2 - V1)$$

$$\frac{R2}{R5} = \frac{R6}{R7} \text{ for best CMRR}$$

$$R1 = R4$$

$$R2 = R5$$

$$\text{Gain} = \frac{R6}{R5} \left(1 + \frac{2R1}{R3} \right) = C(1 + a + b)$$

AC Coupled Non-Inverting Amplifier

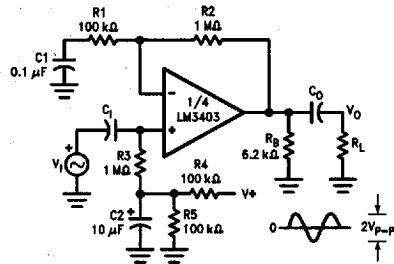

TL/H/10064-9

$$A_v = 1 + \frac{R2}{R1}$$

$A_v = 11$ (as shown)

1

Typical Applications (Continued)

AC Coupled Inverting Amplifier

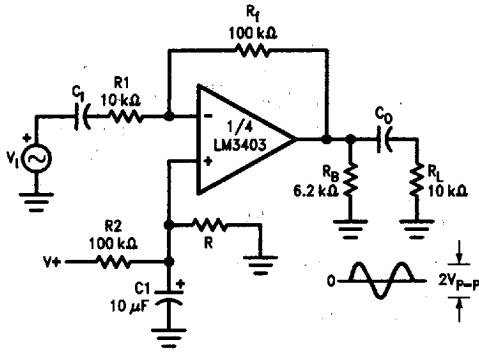

TL/H/10064-8

$$A_v = \frac{R_f}{R_1}$$

$A_v = 10$ (as shown)

Voltage Reference

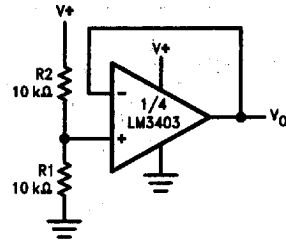

TL/H/10064-10

$$V_O = \frac{R_1}{R_1 + R_2} \left(= \frac{V^+}{2} \text{ as shown} \right)$$

$$V_O = \frac{1}{2} V^+$$

Ground Referencing a Differential Input Signal

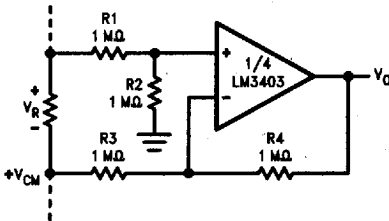

TL/H/10064-11

Pulse Generator

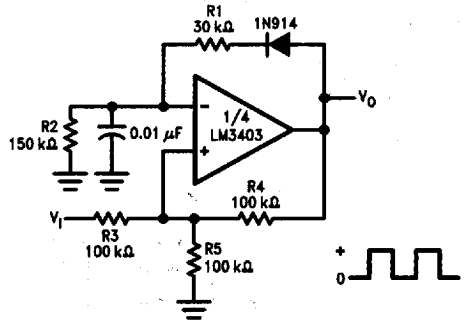

TL/H/10064-14

Voltage Controlled Oscillator

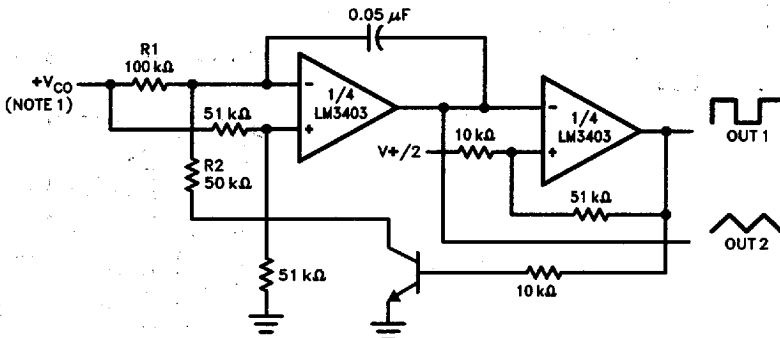

TL/H/10064-12

Note 1: Wide Control Voltage Range:
 $0V \leq V_{CO} \leq 2(V \pm 1.5V)$

Typical Applications (Continued)

Function Generator

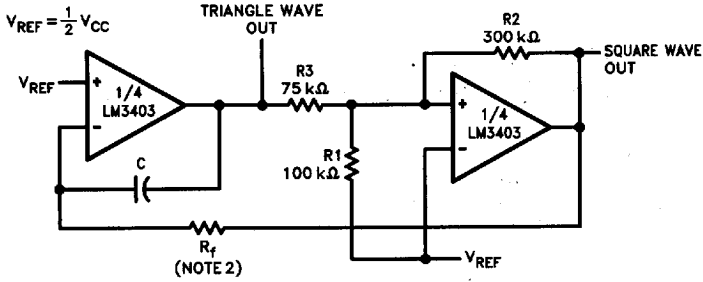

Note 2: $f = \frac{R1 + R2}{4CR1}$ if $R3 = \frac{R2R1}{R2 + R1}$

TL/H/10064-13

Bi-Quad Filter

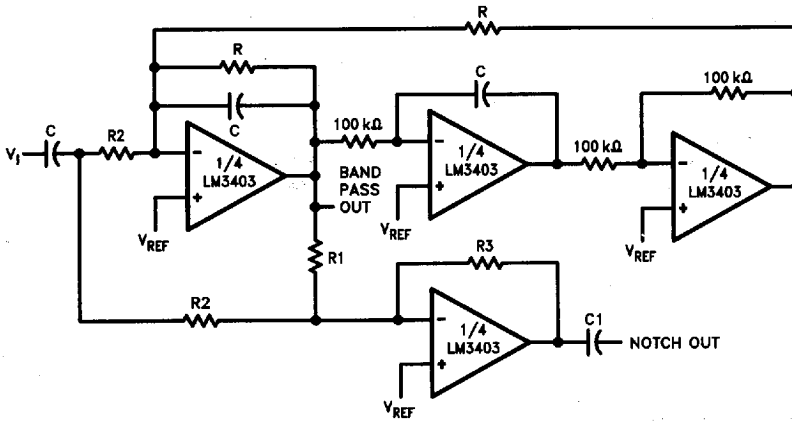

TL/H/10064-15

$Q = \frac{BW}{f_0}$
 where:
 T_{BP} = Center Frequency Gain
 T_N = Bandpass Notch Gain
 $f_0 = \frac{1}{2\pi RC} \cdot V_{REF} = \frac{1}{2} V_{CC}$
 $R1 = QR$
 $R2 = \frac{R1}{T_{BP}}$
 $R3 = T_N R2$
 $C1 = 10 C$

Example:
 $f_0 = 1000 \text{ Hz}$
 $BW = 100 \text{ Hz}$
 $T_{BP} = 1$
 $T_N = 1$
 $R = 160 \text{ k}\Omega$
 $R1 = 1.6 \text{ M}\Omega$
 $R2 = 1.6 \text{ M}\Omega$
 $R3 = 1.6 \text{ M}\Omega$
 $C = 0.001 \mu\text{F}$